



The Flying Wire

**Chapter 124
Experimental Aircraft Association**

**Volume 52 Number 4
April 3, 2013**

Board Meeting - 5:30 pm

Dinner - 6:15 pm

General Meeting - 7:00 pm

Table of Contents

April Program	1
Events Calendar	1
Willits Fly-Out	1
Chapter Facilities Notes	2
Fly Mart	2
News/Notes from the Editor	3
Trivia	3
Wing Tips	4
Board Minutes	5
General Minutes	5
Contact Information	6

www.EAA124.org

www.CafeFoundation.org

www.EAA.org

EAA Chapter 124
5550 Windsor Road
Windsor, CA 95492

PO Box 6192
Santa Rosa, CA 95406

April 3, 2013 Program

Jabiru Heating and Cooling Systems

Our April program will be from Bob Gutteridge. Bob will cover what he's learned about the heating and cooling systems in his Jabiru. Please join us for this interesting presentation.

Events Calendar

Please send us info about upcoming events!

We want to keep everyone informed about local and regional events, so send us information if it comes your way!

Bob Gutteridge: bob_gutteridge@pacbell.net

John Palmerlee: jbpalm@sonic.net

April 14: 3rd Annual Boonville Fly-in & BBQ 11-3pm, Chapter 1027

[Click Here](#) for more info

April 26-27: CAFE Electric Aircraft Symposium VII, Flamingo Hotel, Santa Rosa. [Click Here](#) for more info

May 1: EAA Chapter 124 May Meeting and Dinner, 6:15 pm

May 4: Cloverdale Open Hangar Day and Chapter 124 Young Eagles Flights at Cloverdale Airport. [Click Here](#) for information

May 6-24: SLSA/ELSA Repairman Maintenance Course. Corning Muni Airport (004), CA

May 13-16: "Aluminum Overcast" B-17 at Ukiah Airport on display and giving rides. Hosted by the Willits EAA Chapter 1027. Contact Paul Trexel eaglenestnorth@juno.com

May 30 – June 2: National Biplane Fly-at Freeman Field, KS [Click Here](#) for more info

June 9: Golden West Fly-In at KMYV. This will include an inter-chapter aircraft competition. Discussion at the meeting.

Saturdays – 12 to 1:30pm BBQ at Sonoma Skypark Chapter 1268

First Thursday each month – 11:30 to 1:30 - *Hot Dog Thursday* at Pacific Coast Air Museum

Willits Fly-out

(thanks, Mike Shook)

Some of our chapter members flew to Willits (O28) on March 10 as a fly-out and to participate in a safety seminar offered by Chapter 1027. It was a small group, but a good discussion, and great burritos. Here are a couple photos taken at the event... As you can see, EAA 124 was well represented.



Chapter Facilities Notes (thanks, Larry!)

(I'm leaving these notes in the April issue as encouragement for everyone to assist Larry in the hangar cleanup process. Please take action where indicated.)

1. All EAA Gate AOA card holders - Please email or call in your new AOA badge number and the expiration date to me as soon as you get the new badge. I have to maintain the list per TSA.

2. Any EAA 124 tenants that have personal items in any of the lockers or Bins in the Shade hangar - please Write your name on the bin beside the hasp/lock. We need lockers/bins for aircraft owners and all seem to be locked - I know some are just from persons that have left the site. We need them. And are going to cut the lock off if it is not marked legibly with your name on it. If we cut your lock by mistake - I have a new lock for you - sorry.

3. Any personal items stored in the Shade hangar needs to be under or in the immediate vicinity of your plane. There are a few items that have been there for too many years and need to be claimed by you, or we will dispose of the items.

4. The club has the High Weed Mower (Bechtold Gas driven) that seems to be excess to our needs, and will gladly sell it to anyone that can use it - I figure it is worth at least \$150 - \$175 or make a reasonable offer.

5 The club has about 4 rolls of clear plastic/mylar 5 ft wide x 1000 ft or so - If anyone has a use for this for coverings, to cover those wings that are waiting for the rest of the project to be finished, or??? please let me know I will make you a deal you cannot refuse. One roll; or all. Just ask.

Fly Mart

Wanted: (4-13) Member Don Mackenzie is looking for an aircraft to fly. He'll rent, share, partner or buy a C-182 level aircraft or better. Commercial pilot with Instrument, 1100 hours. Contact

Don with ideas/offers. donm@mackenziesystems.com

For Sale: (3-13) AirTech Fuel Cap Tool. This high tech tool helps pilots open many types of aircraft fuel caps, doors and latches. Contact Ryan Beck, ryan.beck1@yahoo.com for information.

For Sale: (2-13) Jeff Rose electronic ignition system for six cylinder aircraft engine. Never used, new in 1998. Complete with Plugs, wiring and all tech data. \$100. Call CJ @ 799-2878

For Sale: Satellite Phone: (12-12) Iridium 9500 Satellite Phone with 2 batteries, 12v and 120v chargers, case, accessory pouch, reference card and deactivated SIMM card. \$400. Contact Bob, 707-483-1985

For Sale: Taylor Titch project: (11-12) \$2,500/best offer. 60% complete by master craftsman. Covered in fabric silver painting nearly complete. The wings were damaged in two places during a move, [Click Here](#) for pictures. Free delivery in the greater Bay Area. Contact Jenny Hayden 415-308-5944 or ejennyhayden@gmail.com. Project is located at South County Airport, San Martin.

For Sale: (9-12) Corbin Baby Ace N5233: \$8,750. Built by John Lunsford in 1978-9, registered as a Lunsford Baby Ace ELSA. Engine: A-75-8 1418 SMOH. Runs Smooth. Bendix Mags. New oil temp gauge, new 600-6 tires, June '12 annual at Jet Center. March '12 recovery with Stewarts. Hand starts easy. Selling Ace in favor of Ercoupe. Hangar 254 Gun Club. Email stephen@pizzo.com 707-829-7038.

Help Wanted: (6-12) Building a discontinued Falcon 80% build kit, complete. Seeking experienced Falcon Builders for support. [Raymond Hillcrest](#) (707)-963-9281. Angwin Airport.

For Sale: (4-12) RV 6 kit and engine \$25,000. Fuselage is a factory built Quick build. All wings, empennage, control surfaces and some other items are built. Engine was removed from a certified plane in Santa Rosa due to airframe corrosion. The engine is a O320 A2B Lycon rebuild with 250 hours. Has all airframe kit parts except finishing kit. Steve Barnes (707) 972-3582

Wing Rack: (2-12) Free to anyone who can use it. Built for an

RV-9A wing, but should work for other RVs or perhaps other wings as well. Call John Swanstrom 758-9017 or Email John at: john.swanstrom@agilent.com

For Sale: RV6A - Half partnership available. See it [Here](#). Call Chris Wallner at **364-1195**

For Sale: Partially Built Spacewalker 2 project (1930's open cockpit trainer replica). Wings complete less covering, Fuselage factory welded. No Motor. Must See! Call Ted Baggett: **823-5325**

For Sale: Easy Eagle project – Airframe and 3 out of 4 wings are finished, with accessories: wheels, brakes, VW adapter, starter (and more). Price Negotiable. Fuselage Picture [Here](#). See [Great Plains Site](#) for more info. Call Bob Ferguson: **539-5665**

For Sale: Matco Parking Brake model PV-1 plus adapters. Never used. David Lynch **578-2087**

For Sale: 1946 Aeronca 11AC Chief in very good condition. Light sport, fun flyer! Mode C exempt. Contact Kirk Wilder at **895-2949**. Flyer at the following link: [Aeronca Chief Flyer](#)

News/Notes From the Editor...

Flyout to Hayfork – April 20th (from Mike Shook)

Bob Gutteridge and Mike Shook are planning a flyout to Hayfork on April 20th. Hayfork, F62, is about 125 nm north. Let's meet at the EAA hanger at 10am and plan to arrive at Hayfork around noon. The direct route takes you over some mountainous and desolate wilderness, so I usually head to the valley and turn left at Red Bluff, this route is about 150 nm.

Irene's Cafe, about a half mile walk from the airport, is open all day Saturdays. One thing that I'm concerned about is that Hayfork sets in a valley that is occasionally fogged in. We can check the weather before we leave and can use Willows as an alternate. We can discuss this at Wednesdays meeting and hopefully we can join up pilots who have empty seats with people looking for a ride.

FAA: Paper Certificates Expire

Paper certificate holders cannot exercise the privileges of PAPER certificates after March 31, 2013. This includes all certificates that are issued under 14 CFR Part 63 and 65.

To replace your Airmen certificate, visit Airman On-Line Services: [Click Here](#)

FAA: TFR Over San Francisco

Starting April 4, 2013, there is a TFR for VIP movement over San Francisco. See the following for more info: [Click Here](#)

CAFE Electric Aircraft Symposium VII – April 26-27, 2013

Remember that EAA members get a very special rate of \$185 (50% off – applies to students too). This is an awesome event. Use the following link to register with this rate: [CAFE EAS VII](#)

Interesting Aviation Links (thanks, David H, Jason W, Donna T, Bob G, Wayne C, Mike T, Brien S)

GoPro's Nick Woodman at Shelleville – [Click Here](#)

Archeopterix structural failure with parachute - [Click Here](#)

FAA Safety Briefing March/April [Click Here](#)

FAA News, Updates, Forecasts – [Click Here](#)

The EAA Zenith Project – [Click Here](#)

National Geog – Hitler's Stealth - [Click Here](#)

“Test Drive” :-) – [Click Here](#)

Preventing Cam and Lifter Wear – [Click Here](#)

Timeless Voices: Robert “Shorty” Rankin – [Click Here](#)

Airbus Takeoff – Side Stick and nose steering – [Click here](#)

HMS Ambush (nuclear sub) Commissioned – [Click Here](#)

Trivia – Airbus Getting Creative

Thinking ahead to a design using many known features for substantial efficiency improvement, Airbus came up with the following sketch and filed for a patent in 2008. Some of the

features lead to problems that must be addressed, like rear prop strike during takeoff rotation and forward swept wing flutter issues.

However, if these issues are resolved, the benefits could be great: less drag from smaller fuselage cross section and swept forward wing, better emergency control from CL thrust, and much higher bypass efficiency using large non-ducted fans. Here's a Flying Magazine article about it some of you may have seen from June 2012: [Click Here](#)

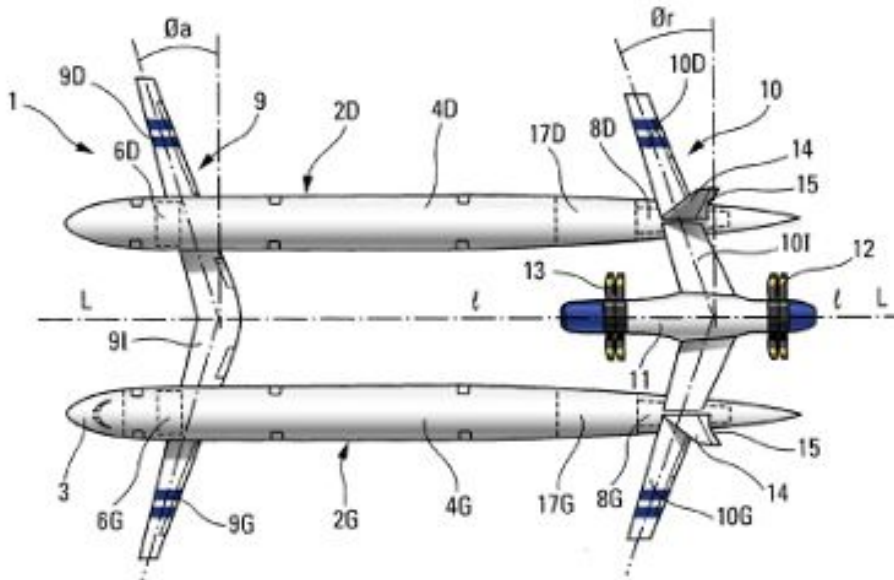

Wing Tips

Inner-Tubes

It's hard to pay big bucks for an inner-tube when you buy new tires for the airplane – heck, they can cost almost as much as the new tire itself. But, an example I'm sure some of you have experienced is pulling on a valve stem of an old tire to get it to seat in the hole, and "off with it's head" it goes!

The valve stem, just like the inner tube, has zero fabric for structural support, but does have a rigid core that forces flexing at

the base of the stem where it joins the tube. As the rubber oxidizes, whatever strength it once had is gone, and is at risk of sudden pressure loss. If a tube and tire are old, but the tire is in good shape, it may be a good idea to replace the tube even before the tire. That old tube will ruin the tire (and more) if it goes while you're rolling.

Always place the inner-tube in the tire carefully to avoid folds in the rubber. Over time, this will lead to creasing and possibly cracking. It's always important to be sure the tube is not pinched between halves of an aircraft wheel. Note how the bolts feel as you tighten them down. They should reach their torque quickly after coming to bear on the wheel halves (no rubber cushion).

You may want to use talcum powder inside the tire so the inner-tube can slide more easily as it is inflated the first time. Try inflating and deflating the tube a couple times to let it seat naturally without wrinkles. I've always used talc, thinking it helped keep oxygen out of the rubber, but I just read an account by the Goodyear Tire company that this is a wives' tale. You decide.

During installation, align the yellow dot on the tube (the heavy spot, if no dot, use the valve stem) with the red dot or triangle on the tire (the light spot). This will minimize imbalance issues during high speed ground ops.

Recheck tire pressure after installing a new tire. It will stretch for the first 12 hours, lowering the pressure.

Some of this information was gathered from the following Aweb resource. The rest of it must be wives' tales! [Click Here](#)

Runaway ELTs

You may have received this Safety Tip in an FAA email, but I thought it's worth including here for those who didn't.

Evidently, ELSs are coming loose – some mounted with velcro or whatever attachment method that makes them easy to move, can fail in an accident, which cause the device to be either damaged or fail to register the G-loading during the impact.

Keep in mind that an ELT aimed in the wrong direction will not register a G-load properly. They are not necessarily omnidirectional like your iPhone :-).

Come to think of it... maybe there could be an ELT app for smart phones that registered excessive g-forces during flight and made some calls, indicating the GPS coordinates of the incident. But don't drop the thing!

The following is a link to the SAIB for anyone interested in more information – [Click Here](#).

EAA Chapter 124 Board Meeting Minutes

March 6, 2013 (Mark Tuma, Acting Secretary)

Called to order 5:35pm by Mike Tovani, VP

(Wayne Cook, President, Absent)

Attendance: Mike Tovani, John Whitehouse, Five other Board members present, Mark Tuma filled in as Secretary.

Old Business:

Meeting being set up with Lori Schaudel about lease.

Facilities:

Weeds will be sprayed next Monday.

AOA Gate cards due this month – Larry needs new card numbers, effects about 20 persons.

Lockers in shade hangar getting new locks.

Members need to clear junk out of hangars not being used.

Wants to sell weed cutter that hasn't been used in a few years.

Treasurer:

In black last month, last chance to get on roster.

VP Report:

Interested in getting someone to organize fun flyouts. Perhaps organize a pancake breakfast and invite other EAA chapters.

PAPA Wednesday March 13 having a corned beef cook.

Larry and John had Presentation of the Year for 2012.

Young Eagles:

May 4th in Cloverdale

CAFE:

No report.

New Business:

None

Round Table:

Runway 19/1 will be 20/2 next year.

Adjourned 6:17pm

EAA Chapter 124 General Meeting Minutes

March 6, 2013 (Mark Tuma, Acting Secretary)

Called to order by Mike Tovani VP, Acting President

(Wayne Cook, President, Absent)

Members and guests welcome.

Thanks to cooks and shoppers.

Minutes approved for January 2013, MSP without change

Treasurer:

In the Black last month due to dues being paid. Last day to pay dues to be in the roster.

Facilities:

Need to renew AOA cards for the gate – Give Larry your # on your card – he is required to keep a roster.

Lockers in shade hangar – need to put your name on the locker or locks will be cut off.

Five Rolls of Mylar in back of shade hangar if you need it – take it.

VP Report:

John and Larry won the best 2012 Program (Smithsonian).

Builders Report:

Three Builders: RV12, RV14, Electric motor glider.

CAFE:

Brien – Electric Aircraft Symposium next month at Flamingo in Santa Rosa. Brien will be speaking at Oshkosh. They are building a new building to exhibit aviation innovations.

Next Electric Aircraft Symposium in April. Go to Cafe's website for more information.

Young Eagles, May 4th, Cloverdale

Webmaster:

Check out links, etc. on website – keep sending in stories and ideas.

Speaker:

Curt from Dynon. Sonoma Jet Center is now a Dynon Dealer.

Adjourned, Mike Tovani

All the calculations show it can't work. There's only one thing to do: make it work.

-Pierre Georges Latécoère, early French aviation entrepreneur

Chapter 124 Contact Information

President: Wayne Cook (13/14) (707) 217-4439
Vice President: Mike Tovani (12/13) (707) 321-2740
Secretary: Austin Rennard (12/13) (707) 326-4452
Treasurer: John Whitehouse (13/14) (707) 539-5549

Board: Ray Shipway (13/14) (415) 584-9682
Frank Higdon (13/14) (707) 537-9850
Mark Tuma (12/13) (707) 953-2403
Jason Wildman (12/13) (707) 523-4361
Tim Peterson (12/13) (707) 538-8860
Jim Duvander (13/14) (707) 838-2174

Facilities Chairman: Larry Rengstorf (12/13) (707) 575-0331

Facilities Committee:

Dwayne Green, Dale Wittman, Jim Long

Technical Counselors:

Bob Gutteridge (707) 539-5188
Jerry Rice (707) 431-0206
Kevin Quirk (707) 539-8589
Doug Dugger (530) 526-4997
Rolf Unternaehrer (707) 763-7729

Flight Adviser: CJ Stephens home: (707) 836-1458
cell: (707) 799-2878

Newsletter Editor, Webmaster: John Palmerlee
jbpalm@sonic.net (707) 566-8560

Young Eagles: Sher & Ray Shipway (415) 999-0949

Librarian: Walt Ferris (415) 482-8331

EAA Chapter 124 5550 Windsor Road Windsor, CA 95492

Meetings are held on the first Wednesday of each month at 7:00 pm. FOOD (\$5) AND SOCIALIZING (free) from 6:15 to 7:00pm. EVERYONE IS WELCOME!

Directions: The site is located on the west side of Sonoma County Airport. Take the Shiloh Road exit from Highway 101 in northern Santa Rosa. Turn left at the stop light (west) and continue to a "T" intersection. Turn left again and follow the road to the EAA sign on the left.

Members are invited to submit articles of interest. You will be notified whether or not an article will appear in the current issue.

Please email articles to: john@eaa124.org
or mail to: John Palmerlee
1209 Hexem Avenue
Santa Rosa, CA 95404

Deadline for newsletter submissions is the 20th of each month. Articles submitted after that date will be included in the newsletter at the discretion of the editor. All articles are copyrighted. To reproduce any article, please contact the editor.

EAA CHAPTER 124 is not responsible for any modification or maintenance items appearing in the newsletter or in any other correspondence. It is the responsibility of the reader to get approval for such items from the appropriate A&P, FAA or other government official.